

# ADD ULTRASONIC WATER METER DESIGNED FOR SMART WATER SOLUTION



*The ADD smart water meter is based on the proven ultrasonic technology and advanced leakage control. The meter maintains its high accuracy throughout its entire lifetime of up to 16 years and allows integration in AMI systems within water/heat/gas/electricity complete solution.*

## FEATURES

### Proven Ultrasonic Technology



- Flow sensor based on proven ultrasonic measurement;
- Two ultrasonic transducers used to send sound signals with/against the flow;
- Not exposed to wear due to impure water;
- Reliability in the long run exploitation.

### Non-revenue water reduction



- Constant monitoring of water consumption;
- Leakage control and report;
- Reliable billing;
- Reduction of non-revenue water consumption and expenses.

## Accuracy



- High accuracy meter:
- Accuracy class 2;
  - No moving parts ensures the same accuracy during the entire lifetime;
  - Low start flow down to 2 l/hour provides measurement of very low flows;
  - The flow velocity does not influence the meter accuracy.

## Communication



Flexible communication options include:

- RF for WAN;
- Bluetooth to control ADD shut-off valve.

## Intelligent Alarms



Supports the following alarm types:

- Leakage;
- Burst;
- Dry;
- Reverse flow;
- Tampering.

Provides indication on the display.

## Data Registering and Storage



- The meters record hourly, daily, monthly data on water consumption;
- Leakage and tampering reports to analyze troubleshooting;
- Daily data storage capacity is not less than 24 months.

## Display

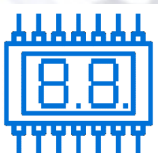

- LCD, 8 digits, easy readable;
- View of measurement data, states, info codes;
- WAN signal level indication.

## Measurement



- Dual temperature monitoring: the meter records the ambient temperature and the water temperature;
- Target volumes can be selected from a wide range;
- Max & min flows depends on the chosen configuration.

## Battery



- The meter is equipped with a lithium battery;
- Battery lifetime up to 16 years under normal operating conditions.

## Design



- The meter case is made from durable composite material;
- Brass measuring pipe;
- Meter houses are sealed and fully water resistant;
- IP68 Protection class;
- Metrological test output to control the metrological parameters during verification;
- Display to view measurement data and alarms;
- Easy mounting onto a water pipe;
- Suitable for outdoor installation.

## Standards



Compliant with:

- ISO 4064 (OIML R49)
- MID Directive (2014/32/EU)

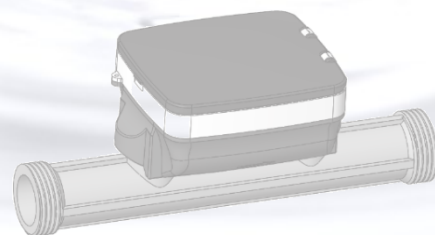

# TECHNICAL SPECIFICATIONS



Characteristic	Value		
<b>Model</b>	WMP15	WMP20	WMP25
<b>Nominal diameter</b>	DN15	DN20	DN25
<b>Permanent flow rate, Q3 (m<sup>3</sup>/h)</b>	1.6	2.5	4
	2.5	4	6.3
<b>Thread</b>	G3/4"	G1"	G1¼"
<b>Dynamic range Q3/Q1</b>	R250 R400		
<b>Installation sensitivity class</b>	U0/D0		
<b>Temperature class</b>	T50 (0.1 – 50 °C)		
<b>Storage temperature</b>	From -25 to 70 °C		
<b>Metrological class</b>	Class 2		
<b>Maximum Admissible Pressure (MAP), bar</b>	16		
<b>Pressure loss</b>	Δp40		
<b>Protection class</b>	IP68		
<b>Environmental class</b>	E1, M1		
<b>Installation</b>	Horizontal or vertical		
<b>Battery</b>	Lithium battery, up to 16 years lifetime in case of meter reading once per day		
<b>Interfaces</b>	Bluetooth		
<b>WAN Communication</b>	LoRaWAN or WM-BUS, SigFox (optionally) Different frequency ranges (optionally): 433 MHz, 868 MHz, 915 MHz, 923 MHz.		
<b>Metrological LED</b>	10 000 imp/m <sup>3</sup>		

Dimensions (mm)	WMP15	WMP20	WMP25
<b>Measuring pipe length (brass)</b>	110/165	130/195	150/190/225
<b>WM dimensions (HxDxB)</b>	71x80x91	77x80x91	85x80x109

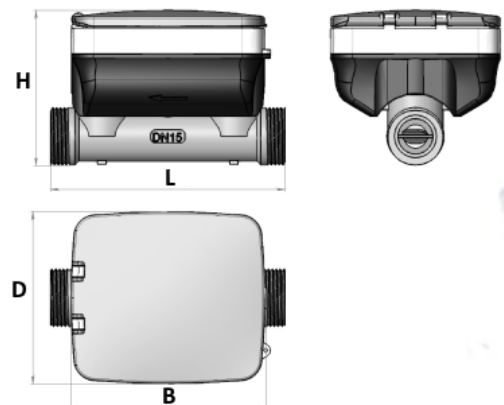

36, Dragomirna str. Kishinev, MD-2008, Republic of Moldova  
**Phone:** +373 22 930 012 **Fax:** +373 22 930 012

