



add new tech to your business!

Datasheet

DC2S DATA CONCENTRATOR/ BALANCE METER



DC2S.13-1

MULTI-FUNCTION SMART DEVICE





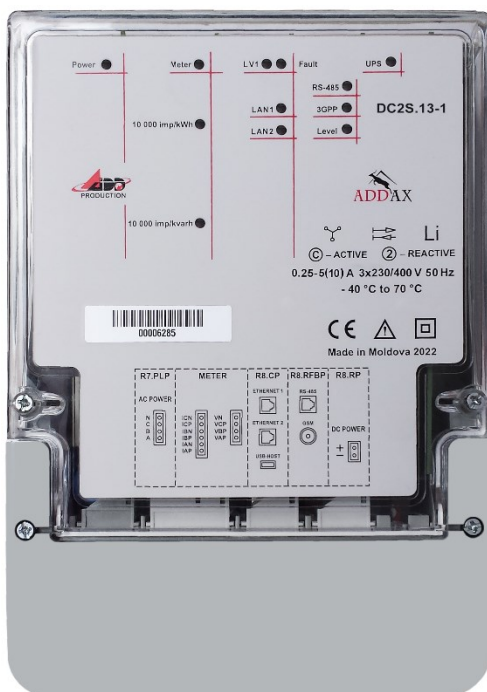



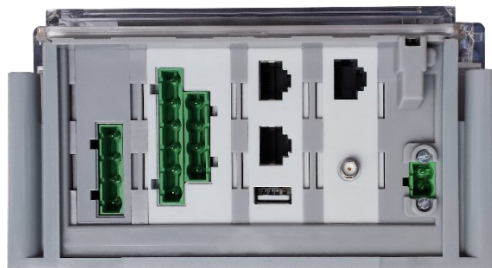





Provides combined functionality of balance meter and data concentrator

GENERAL VIEW



INTERFACES



-  Automatic detection, registration and support of end-point devices within the network
-  Full 2-way communication
- PLC** Built-in LV PLC modem
-  2 Ethernet ports for LAN/WAN communication
-  USB interface
-  RS-485 communication channel
-  2G/3G/4G communication module
- IPSec** Secure data transmission
-  Firmware update (local/remote)
- KWh
KVarh
VAh** Active energy (export/import)
Reactive energy (4 quadrants)
Apparent energy
-  Scheduled data collection
-  Event Logs
-  Data storage in non-volatile memory
-  Built-in real-time clock
-  Backup power supply; possibility to connect external power supply
-  Tamper detection sensors
-  Authentication & Encryption

DLMS/COSEM SUPPORT

- Standard data model.
- Standard communication protocols.
- Interoperability.

BUILT-IN CLOCK

- Real Time Clock (RTC).
- RTC accuracy 0,5 s /24 h. (IEC 62052-21).
- Network Time Protocol (NTP) for clock synchronization.
- Support in backup supply mode.
- Automatic changeover for daylight saving time.

MEASURED QUANTITIES

- Active energy, accuracy class 0,5S (C), export and import.
- Reactive energy, accuracy class 2, 4 quadrants.
- Apparent energy.
- Power, Max Demand
 - integration period: 15', 30', 60', day;
 - average interval: day, month.
- Voltage, instantaneous value, RMS.
- Phase current.

METERING DATA

- Actual meter readings
- Periodic (daily, monthly) meter readings
- Interval (5', 10', 15', 20', 30', 60') meter readings
- Timestamp.

DATA STORAGE

- Non-volatile memory.
- Long term data storage.
- Storage capacity depends on number of meters assigned to the DC2S and number and type of the subscribed data.

MULTI-RATE METERING

- Up to 6 tariff registers.
- Up to 12 changeovers per day.
- Active and passive tariff plans, configurable activation time of the passive tariff plan.

CALENDAR

- Up to 12 seasons per year.
- Up to 8 daily and weekly profiles.
- Up to 30 special days per year.
- Support of movable holidays.

SOFTWARE UPGRADE

- Managed meters remote update by P3.2 protocol or WEB interface.
- Remote DC firmware update by Web browser (also local) or HES application.
- DC automatic update from the stated URL at scheduled time.

INFORMATION SECURITY

- Communication encryption protection (AES-128 bit key).
- HTTP secure protocol.
- Support of VPN-tunneling (IPSec protocol).
- Data access according to access rights stated.
- Firmware protection

INDICATION LEDs

- Test outputs: active/reactive/energy LEDs.
- DC2S communication LEDs (placed on DC2S nameplate) to reflect status of available interfaces (LV, Ethernet, RS-485, 2G/3G/4G).
- Power supply and UPS LEDs.

ELECTRICAL ENERGY QUALITY CONTROL

- Quality indexes:
 - average voltage;
 - voltage sags and swells;
 - outages;
 - network frequency;
 - total harmonic distortion (THD);
- Remote or local configuring of parameters thresholds.

FRAUD PROTECTION

- DC case and terminal block opening sensors.
- Continuous monitoring of opening sensors, including backup supply mode.
- Two protective seals for each cover (DC and terminal block).
- Secure design: terminal block cover cannot be opened without removing DC cover.

EVENTS & ALARMS HANDLING

- Continuous control of DC2S current state in real time mode:
 - managed devices registration/unregistration,
 - power failures,
 - tamper attempts,
 - communication events,
 - firmware update etc.
- Events processing, storage and reporting:
 - registration in different event logs,
 - event report sending,
 - state presentation by LEDs and optionally on CIU display.
- Immediate notification to HES in case of alarms.
- Timestamps.

NETWORK DEVICES SUPPORT

- Automatic detection and registration of network devices.
- Support of up to 1,000 end-point devices. The number of supported devices can be increased for special cases.

ADDRESSING MODE

- Unicast, broadcast and multicast modes of transmission.

DATA COLLECTION

- On request.
- By preliminary set schedule.
- On event occurred.

PARAMETERIZATION

- Remotely or locally via Ethernet interface.
- DHCP support.
- Web-interface as a parameterization tool.

COMMUNICATIONS

- LV PL communications - OFDM PLC in the CENELEC A band and FCC band:
 - ITU-T G.9904 (PRIME) standard compliance. Supports PRIME 1.3.6 with possibility to be upgraded to PRIME 1.4.
 - ITU-T G.9903 (G3-PLC FCC) standard compliance.
- Ethernet interface:
 - Two RJ-45 ports for LAN and WAN communication, 10/100 BASE-T Ethernet IEEE 802.3 standard compliance.
- USB interface:
 - USB 2.0 Full Speed standard compliant, can be used for local communication.
- RS-485 interface
 - TIA/EIA-485 standard compliant used for communication with external devices.
- 2G/3G/4G communication
 - 2 SIM cards support;
 - automatic switching between 2G/3G/4G modes.

BACKUP POWER SUPPLY

- Battery to support RTC and opening sensors in backup supply mode; lifetime up to 20 years.
- Rechargeable batteries and possibility to connect the external power supply (UPS) in case of power failure.

TECHNICAL SPECIFICATIONS

Nominal voltage, U_n	3 x 230/400 V \pm 20%
Reference frequency, F_n	50 Hz \pm 2%
Reference current, I_b	5 A
Accuracy class (active energy)	C (0.5s)
Accuracy class (reactive energy)	2
Maximum current, I_{max}	10 A
Maximum active consumed power	12 W
Average total consumed power	30 VA
Operation temperature range, T_n	-40 °C ... +75 °C
Storage and transportation temperature	-40 °C ... +85 °C
Difference between temperature of internal parts and environment (less than 55 °C)	30 °C
Clock accuracy (at 25°C) (IEC 62052-21)	\leq 0.5 s /24 h
The variation of the time-keeping accuracy with the temperature from - 40 °C to +75 °C, not more than	\pm 0.1 s/°C/24 h
Impulse voltage (IEC 62052-11)	12 kV, 1.2/50 μ s, 40 Ohm
Insulation protection	Class 2
Electrostatic discharge (IEC 61000-4-2)	15 kV
High frequency radiant field (IEC 61000-4-3)	10 V/m
High frequency interferences (IEC 61000-4-4)	4 kV
Surge immunity test (IEC 61000-4-5)	6 kV
Voltage fluctuations, not more than	1 s
Mean time between failures (at fault probability of 0.8)	24 000 hours
IP rating	IP54*
Mean total lifetime, not less	20 years
Dimensions, L x l x h	241x170x88 mm
Mass, not more than	1.25 kg

CONNECTION DIAGRAM

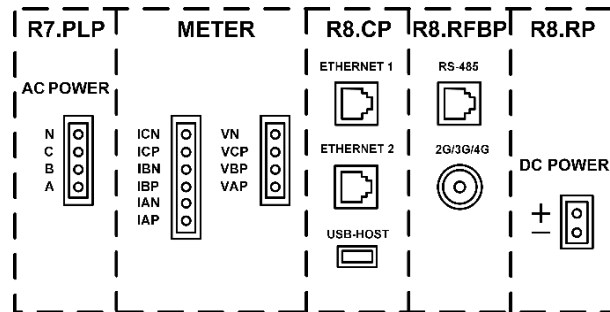

HOUSING

- Light-tone non-flammable polycarbonate
- IP 54 protection against water and dust

MOUNTING

- Fastening in three points in vertical position

CONTACT US



36, Dragomirna str.
Kishinev, MD-2008,
Republic of Moldova

Phone : +373 (022) 930 012

Fax : +373 (022) 930 012

E-mail : info@addgroup.com

Web : www.addgroup.com

* In case of outdoor installation, the DCU should be obligatory installed inside the protective box.