



ADDAX IMS Communications

GENERAL DESCRIPTION

Contents

- Overview 7
- 1. General Concepts of ADDAX IMS Solution 8
- 2. PL Communications 9
- 3. RF communication.....Ошибка! Закладка не определена.
- 4. PLC+RF Hybrid solution11

Revision History

| Version | Author | Date | Comments |
|---------|--------------------------|------------|--|
| 1.0 | Bacalim Ecaterina | 25.07.14 | Original document |
| 1.1 | Deinikovskaia Natalia | 18.02.14 | Sections 3, 4, 4.1, 5, 5.1, 5.2, 5.3, 6, 7, 8, 9 are revised. Figures 1, 2, 4, 6, 7, 8, 9, 14, 15 are revised. |
| 1.2 | Solomon Elena | 08.08.16 | Section 10 was added |
| 2.0 | Sergei Druta | 23.03.2018 | Whole document was revised |
| 2.1 | Dimov Daniela | 16.09.2020 | Whole document was revised |

Terms and Abbreviations

| Term | Description |
|-------------------------|--|
| 2G | GSM/GPRS communication |
| 3G | UMTS communication |
| 3GPP | 3rd Generation Partnership Project |
| 4G | LTE communication |
| 6LoWPAN | <p>6LoWPAN is an acronym of IPv6 over Low power Wireless Personal Area Networks.</p> <p>The 6LoWPAN concept originated from the idea that "the Internet Protocol could and should be applied even to the smallest devices," and that low-power devices with limited processing capabilities should be able to participate in the Internet of Things.</p> <p>The 6LoWPAN group has defined encapsulation and header compression mechanisms that allow IPv6 packets to be sent to and received from over IEEE 802.15.4 based networks. IPv4 and IPv6 are the work horses for data delivery for local-area networks, metropolitan area networks, and wide-area networks such as the Internet. Likewise, IEEE 802.15.4 devices provide sensing communication-ability in the wireless domain. The inherent natures of the two networks though, are different.</p> |
| ADDAX IMS | Integrated Metering System based on ADDAX Technology |
| AMI | Advanced Metering Infrastructure |
| CIU | Customer Interface Unit |
| CM | Communication Module |
| DC | Data concentrator |
| DCS | Data collection system |
| HAN | Home Area Network - includes water, gas, heat, etc. meters, Customer Interface Units (CIU) |
| HES | Head-end system |
| IP address | An Internet Protocol address is a numerical label assigned to each network device (e.g., computer, concentrator) participating in a computer network that uses the Internet Protocol for communication |
| IPSec | Internet Protocol Security is a protocol suite for securing Internet Protocol (IP) communications by authenticating and encrypting each IP packet of a communication session |
| LLC | <p>Stands for the Logical Link Control data communication protocol layer is the upper sub-layer of the data link layer (which itself is layer 2, just above the physical layer) in the seven-layer OSI reference model. It provides multiplexing mechanisms that make it possible for several network protocols to coexist within a multipoint network and to be transported over the same network media, and can also provide flow control and automatic repeat request (ARQ) error management mechanisms.</p> <p>The LLC sub-layer acts as an interface between the media access control (MAC) sublayer and the network layer</p> |
| LV | Low Voltage (0,4 kV) |
| MAC | Stands for the Media Access Control data communication protocol sub-layer, also known as the medium access control, is a sublayer of the data link layer specified in the seven-layer OSI model (layer 2). It provides addressing and channel access control mechanisms that make it possible for several terminals or network nodes to communicate within a multiple access network that incorporates a shared medium, e.g. Ethernet. The hardware that implements the MAC is referred to as a medium access controller |
| M-Bus (Wireless) | Wireless/Wired Meter-Bus was developed to fill the need for a system for the networking and remote reading of utility meters, for example to measure the consumption of gas or water in the home. |
| MDMS | Meter Data Management System |

| Term | Description |
|--------------------|--|
| OFDM | In telecommunications, orthogonal frequency-division multiplexing is a type of digital transmission and a method of encoding digital data on multiple carrier frequencies |
| OSI model | Stands for the Open Systems Interconnection model that is a prescription of characterizing and standardizing the functions of a communications system in terms of abstraction layers. Similar communication functions are grouped into logical layers. An instance of a layer provides services to its upper layer instances while receiving services from the layer below |
| PDU | Protocol Data Unit |
| PHY | Is an abbreviation for the Physical Layer of the OSI model. The physical layer or layer 1 is the first and lowest layer in the seven-layer OSI model of computer networking. The physical layer consists of the basic hardware transmission technologies of a network. It is a fundamental layer underlying the logical data structures of the higher level functions in a network. The physical layer defines the means of transmitting raw bits rather than logical data packets over a physical link connecting network nodes. The bit stream may be grouped into code words or symbols and converted to a physical signal that is transmitted over a hardware transmission medium. The physical layer provides an electrical, mechanical, and procedural interface to the transmission medium. The shapes and properties of the electrical connectors, the frequencies to broadcast on, the modulation scheme to use and similar low-level parameters, are specified here. |
| PLC | Power Line Carrier |
| RS-485 | ANSI/TIA/EIA-485, TIA/EIA-485, EIA-485 or RS-485, is a standard defining the electrical characteristics of drivers and receivers for use in balanced digital multipoint systems |
| SIMS Client | The main client application of ADDAX metering system |
| S-FSK | Spread frequency-shift keying is a frequency modulation scheme in which digital information is transmitted through discrete frequency changes of a carrier signal |
| TCP | The Transmission Control Protocol (TCP) is one of the core protocols of the Internet protocol suite (IP), and is so common that the entire suite is often called TCP/IP |
| TIA/EIA-485 | Telecommunications Industry Association/Electronic Industries Alliance |
| UART | A Universal Asynchronous Receiver/Transmitter is commonly used in conjunction with communication standards such as EIA, RS-232, RS-422 or RS-485 |
| UDP | The User Datagram Protocol (UDP) is one of the core members of the Internet protocol suite (the set of network protocols used for the Internet). With UDP, computer applications can send messages, in this case referred to as datagrams, to other hosts on an Internet Protocol (IP) network without prior communications to set up special transmission channels or data paths |
| VDCU | Virtual Data Concentrator Unit |
| VPN | Virtual Private Network, extends a private network across a public one, such as the Internet |

Normative references

ADDAX IMS communications support the requirements of the following international standards:

| | |
|-------------------------------|--|
| IEEE 802.3 | Standards for Ethernet networks. ADDAX RTR/DCU supports 10/100 BASE-T Ethernet interfaces |
| PRIME specifications | ITU-T G.9904. Narrowband orthogonal frequency division multiplexing power line communication transceivers for PRIME networks |
| G3 specifications | ITU-T G.9903-201210. ITU-T. Transmission Systems And Media, Digital Systems And Networks Access Networks – In Premises Networks |
| 2G: 3GPP TS 27.005 | Technical Specification Group Terminals; Use of Data Terminal Equipment - Data Circuit terminating Equipment (DTE-DCE) interface for Short Message Services (SMS) and Cell Broadcast Service (CBS) |
| 3GPP TS 27.007 | Technical Specification Group Core Network and Terminals; AT command set for User Equipment (UE) |
| 3GPP TS 27.010 | Terminal Equipment to User Equipment (TE-UE) multiplexer protocol (Release 1999) |
| 3GPP | 2G 3GPP Release 99 3G 3GPP Release 7 4G 3GPP Release 9 |
| ANSI/TIA/EIA-485 | Electrical Characteristics of Generators and Receivers for Use in Balanced Multipoint Systems |
| EN 13757-2 | Communication systems for and remote reading of meters” – Part 2: Physical and link layer |
| EN 13757-3 | “Communication systems for and remote reading of meters ” – Part 3: Dedicated application layer |
| EN 13757-4 | Communication systems for meters and remote reading of meters. Wireless meter readout (radio meter reading for operation in the 868-870 MHz SRD band) |
| EN 300 220 | Electromagnetic compatibility and Radio spectrum Matters (ERM); Short Range Devices (SRD); Radio equipment to be used in the 25 MHz to 1 000 MHz frequency range with power levels ranging up to 500 mW |
| EN 301 489 | Electromagnetic compatibility and radio spectrum matters (ERM); ElectroMagnetic Compatibility (EMC) standard for radio equipment and services |
| EN 60950 | Information technology equipment Safety |
| IEC 61038 | Electricity metering. Tariff and Load control. Particular requirements for time switches |
| IEC 60730 | Safety Standard for Household Appliances (Class B Safety Library) |
| IEC 61334-5-1 | Distribution automation using distribution line carrier systems. Lower layer profiles. The spread frequency shift keying (S-FSK) profile |
| IEC62056-47 | Electricity metering - Data exchange for meter reading, tariff and load control - Part 47: COSEM transport layers for IPv4 networks |

Overview

ADDAX Metering Solution provides meter reading, data collection, processing and analysis functions. To implement all of these functions various communication technologies and protocols are used. The purpose of this manual is to give the user an overview of the communication technologies used in ADDAX IMS solutions.

An AMI system refers to a combination of metering, communication, information, and control devices, able to monitor, manage, and optimize the interaction between the utility companies and the consumers. It aims at improving the reliability, safety, and security of data collection from metering devices. In order to achieve these targets, an appropriate two-way communication infrastructure is required, that is able to exchange and deliver real-time data in an automated way.

The communication network of an AMI can be categorized into three hierarchical levels with respect to the coverage area, data rate, and functionality: short-range networks (including home area networks (HANs)), medium-range networks (including local area networks (LANs)), and long-range networks (known as wide area networks (WANs)).

HANs are required at the end user level to provide communication facilities for the implementation of functionalities pertaining to the energy consumption. The communication infrastructure needed for this level should provide a low-cost and energy-efficient communication with acceptable security and reliability level for short coverage distances (up to 100 m) and low data transfer rates.

LANs provide communication facilities for data collection. The communication infrastructure at this level has to provide reliable and secure data transfer for larger coverage areas (up to 10 km) with higher data transfer rates, to provide communication facility for a large number of metering units and data concentrators.

WANs as the communication backbones connect several distributed small communication networks to each other. In the AMI, the WAN facilitates the communication between data collection infrastructure and the HES. The communication infrastructure at this level should provide communication for large coverage areas (up to 100 km) with high data transfer rates in a secure and reliable manner.

There are many different methods of communicating between connected meters and the HES, including PLC, cellular, RF mesh, and other medium to long range solutions. In determining the best communication method, you have to relate its capabilities to the specific needs of the region/network.

For the proper selection of the communication technology, a variety of issues, including the features of the region and the topology of the power grid must be taken into account. Sometimes several different technologies are applied within the same network. The media type and network topologies provide various capabilities of speed, security, reliability and availability of the systems.

All used communication technologies are subject to the following requirements:

- **Bandwidth:** the frequency range used for data transfer;
- **Coverage area:** the physical area where the communication is available;
- **Data rate:** the amount of data transferred within a certain time duration;
- **Latency:** the time required to exchange data from the source to the destination;
- **Reliability:** the availability of data transfer system and its ability for data exchange;
- **Noise immunity:** the ability of the system to perform its functions in harsh network conditions (interference presence);
- **Minimal price and operating costs;**
- **International standards compliance;**
- **Security:** concerned with authenticity, availability, confidentiality, integrity, and nonrepudiation.

1. General Concepts of ADDAX IMS Solution

In order to deal with the bidirectional flow of power and data over the network, providing reliability, availability, security, scalability, and a cost-effective communication infrastructure, ADDAX IMS grounds on the following principles:

| | |
|---------------------------|---|
| Standard protocols | ADDAX IMS is an open standard-based solution which provides interoperability and interconnectivity with measuring devices and compatible components (hardware/software) of the AMR/AMM/AMI systems produced by other manufacturers. |
| Flexible solution | The metering solution can be seamlessly expanded from a small project to a large operated system. Quick and seamless deployment based on "plug & play" technology essentially decreases installation and maintenance costs. Auto-discovery function makes it easier to integrate the newly installed devices. |
| Future proof base | Using of standard and widespread interfaces facilitates adaptation to actual and integration of future communication technologies. |

ADDAX IMS solution is based on a standard three-level architecture; the main communication technologies used are: PL communication or hybrid PLC+RF solution for last mile communications, and 3GPP/Ethernet (see details in Figure 1). Additionally ADDAX meters communicate with HAN devices via RF, RS-485 or Bluetooth interface.

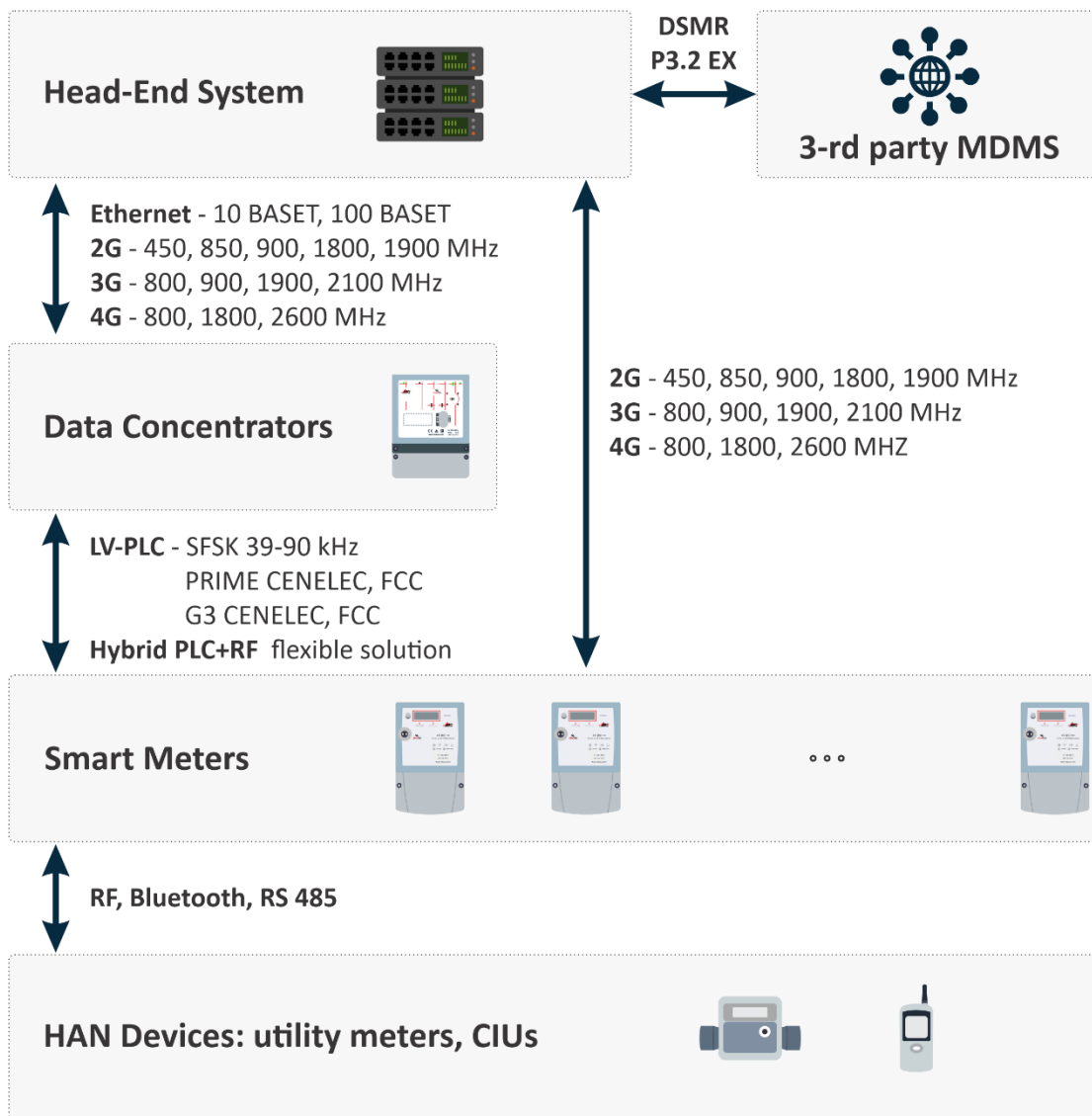

Figure 1. ADDAX Solution architecture

2. PL Communications

PLC - Power Line Communication is a generic term defining all possible technologies that use the power networks as communication media. PLC technology can be roughly divided into two types - narrowband PLC and broadband PLC. Narrowband PLC works at lower frequencies (3-500 kHz), lower data rates (up to 100s of kbps), and has longer range (up to several kilometres). Narrowband PLC is generally used for home automation, smart metering, or as a component of the Smart Grid.

Broadband PLC works at higher frequencies (1.8-250 MHz), high data rates (up to 100s of Mbps) and it is used in shorter-range applications (internet service and home area network (HAN) applications).

One of the most important requirements for PLC applications is that all of the components need to be resilient to any noise or unintended interference. Consequently, the efforts are directed to make systems work in harsh environments with the required availability and performance.

Table 1. PLC frequency ranges allowed for PLC communication on power grid

| Regulatory body | Frequency band | Note |
|-----------------|----------------|---|
| CENELEC | 3-95 kHz | A – Energy providers |
| | 95-125 kHz | B – Reserved for users |
| | 125-140 kHz | C – Reserved for users, regulated CSMA access |
| | 140-148 kHz | D – Reserved for users |
| FCC | 10-490 kHz | |

Why choose PLC:

When choosing PLC technology, the grid characteristics (the topology details, wiring practices, and cable types) and application domain (end users density per subnetwork) should be considered, seeing that the signal propagation and noise characteristics are very dependent on these factors. PLC might is not always the best solution, especially if the distance between nodes is too large (signal repetition is required), or if the total number of customers is not large enough to allow the return on investment.

In the following, a short overview on the key features of the power line channel is provided:

- Open, royalty-free and multi-vendor interoperable standardized technology.
- Cheap and easy to implement - no separate channel establishment required other than the pre-existing power lines. Power grid is an all-over network, which reaches the end users with little investments.
- Optimized for automated meter infrastructure (AMI) with its high efficiency - supports large scale meter reading and management applications.
- Registration of devices as radio frequency equipment is not required.
- Addresses security and data privacy issues.

Possible challenges:

There are several factors impairing the performance of the Power line communications:

- Due to the different structure of the power network in different countries and to the lack of some universal regulations for PLC communications or power grids, special measures have to be implemented to ensure compatibility of different devices.
- The communication channel is strongly affected by the grid characteristics (physical topology, quality of electrical wiring, type/mode/power of plugged in electrical appliances and devices, etc.), as a result, there is a decrease in the data transfer rate.
- Data communication reliability may drop down due to the noisy channel conditions, varying impedance, high levels of frequency-dependent attenuation are the main issues.
- Interferences with devices emitting short-wavelength range may occur, especially amateur radio service devices.

- Electromagnetic interference (EMI) may occur, due to unshielded power lines.

To improve PLC operation in harsh grid conditions, to maintain signal integrity, and maintain reliable data transmission, technologies and equipment are required. In the following PLC technologies implemented within ADDAX IMS are presented.

ADDAX solution aspects:

Power Line communication over low voltage network is the main type of communications used between ADDAX meters and data collection equipment. It uses existing Low Voltage Power Lines (0,4 kV), thus providing a low-cost transmission of data.

Key features:

- EMC standards compliance;
- Frequency range according to CENELEC or FCC;
- Automatic network building;
- DLMS/COSEM compliance.

Data exchange through PLC on the customer side is provided by the ADDAX Smart Meters. On utility side the communication is supported by Data Concentrators or Gateways (see Figure 2).

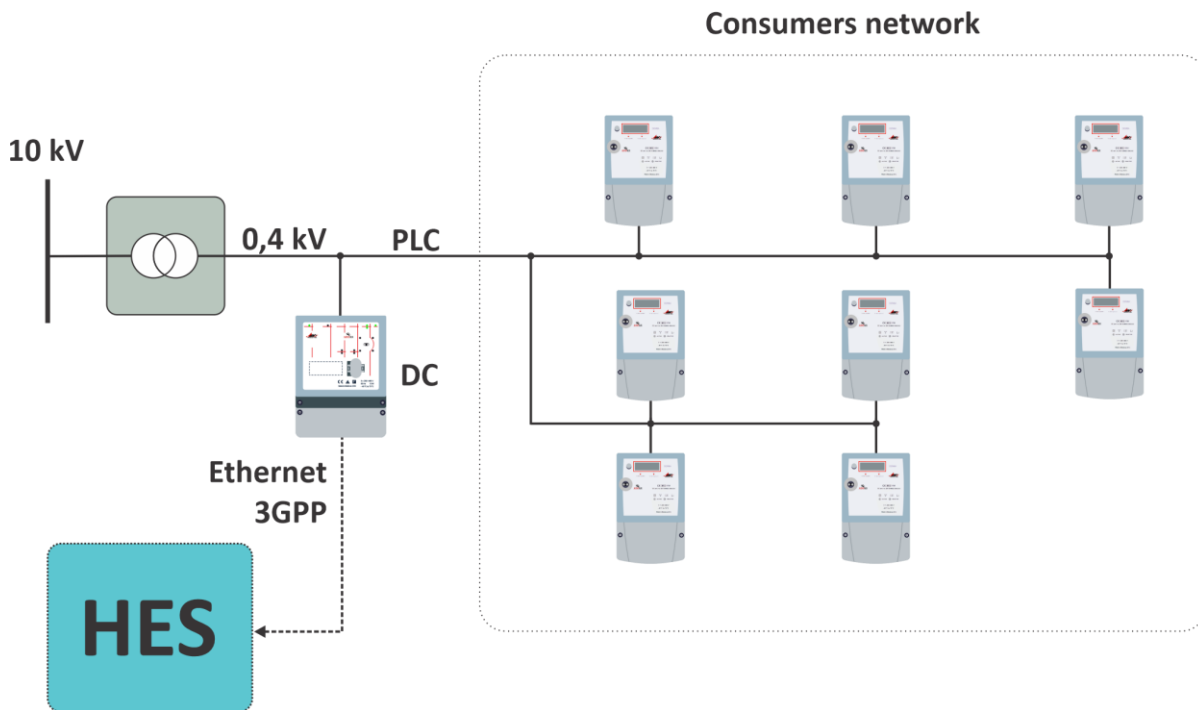

Figure 2. General scheme of data transmission via PL LV communication channel

Any ADDAX device with PLC-modem can operate as a repeater on the long network distances. For S-FSK and PRIME OFDM the maximum possible distance subject to the repetition mechanism can reach more than 2.5 km (8 levels x 350 m). For G3 OFDM the number of repetition levels is not limited.

Various standards have been developed for PLC in order to ensure reliable communications and inter-operability. The developed standards are focusing on different performance factors and issues relating to particular applications and operating environments.

Several modulation technologies for PLC are supported by ADDAX equipment:

Table 3. S-FSK, PRIME and G3-PLC main parameters

| | S-FSK | PRIME | G3-PLC |
|--------------------------|---|------------------------------------|--|
| Standards compliance | IEC61334-5-1 | PRIME 1.3.6 or 1.4 ITU-T G.9904 | G3-PLC ITU-T G.9903 |
| Frequency range | 30-90 kHz | 42-89 kHz | 35-90 kHz |
| Sampling frequency f_s | 192 kHz | 250 kHz | 400 kHz |
| No of carriers | 2 | 97 | 36 |
| Subcarrier spacing | ≥ 10 kHz | 488 Hz | 1.5625 kHz |
| FFT size | Not used | 512 | 256 |
| Length of cyclic prefix | Not used | 48 | 30 |
| Windowing | Not used | no | yes |
| Max. data rate | 2400 bps | 64 kbps | 33.4 kbps |
| Forward Error Correction | Not used in standard solution (convolutional coding added as a proprietary extension) | convolutional code | Reed Solomon code, convolutional code, repetition code |
| Interleaving | Not used | per OFDM symbol | per data packet |
| Modulation | S-FSK | DBPSK, DQPSK, D8PSK | ROBO, DBPSK, DQPSK, D8PSK |

When discussing communication technology, it is often useful to refer to the 7-layer OSI model. Some PLC chips can implement only the Physical Layer of the OSI model, while others integrate all seven layers. ADDAX PLC modem with its variations supports the collapsed standard communication protocol presented below:

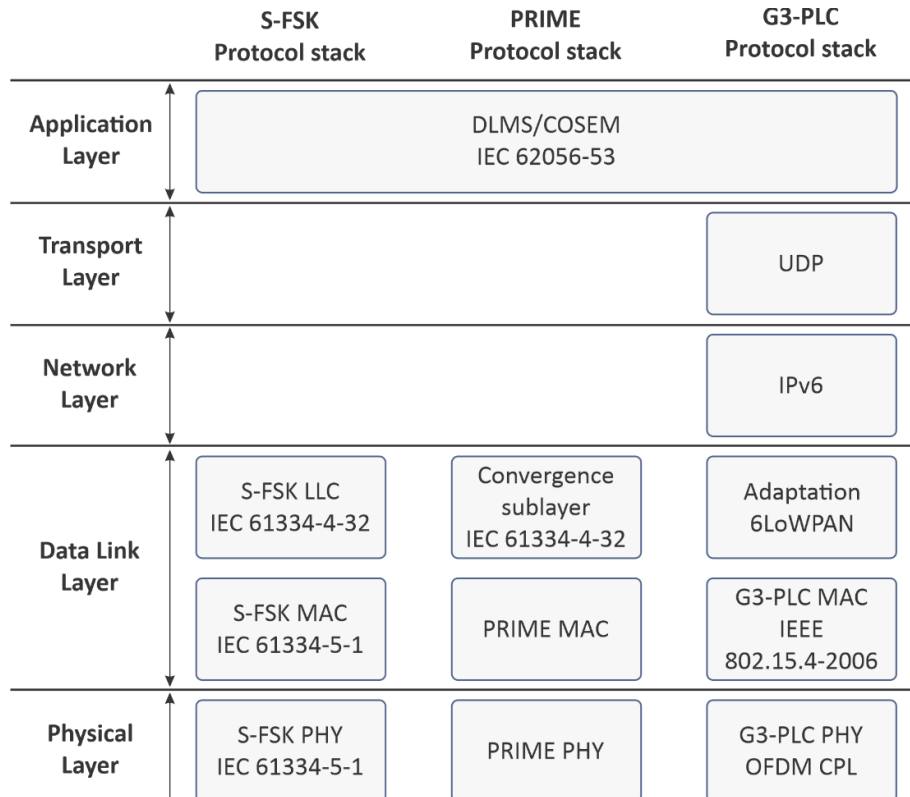

Figure 3. ADDAX PL LV protocol stack

3. PLC+RF Hybrid solution

The majority of networks consist of sectors with diverse characteristics: long distances, variable consumer density, presence of a large number of noise-generating equipment, etc., which in

sum make from the network a complex environment, requiring efficient and reliable solutions to overcome the variety of conditions. In some cases, none of the communication technologies can consistently realize high performance on their own. This way hybrid solution was introduced, as it combines the capabilities of mostly used communication technologies - RF and PLC, enabling to improve the coverage and connectivity, at a reasonable cost.

The G3-PLC Hybrid is the first industry hybrid standard offering extended capabilities for smart metering applications in one seamlessly managed network over PLC and RF media. The protocol stack is built on open standards IEEE 802.15.4-2015 in addition to the existing ITU-T G.9903 G3-PLC protocol.

The channel selection between adjacent nodes in the network is done automatically and adjusted dynamically, depending on the actual conditions of the network. The G3-PLC Hybrid profile is compatible and interoperable with existing G3-PLC or RF implementations, making possible to mix hybrid and non-hybrid nodes.

Why choose hybrid solution:

The advantage of the hybrid solution relies not only on its flexibility but also on combining the best aspects of both most popular in smart metering technologies PLC and RF:

- **Improved reliability of data collection** - if one of the interfaces fails for any reason, the device will automatically switch to another interface.
- **High noise immunity**
- **Reducing the cost of operating and maintaining equipment**
- **Maximizes coverage and resilience.**

RF communication technology is the second most popular option for an IMS; used as an alternative to a physical network media it helps to save the cost and time on physical installation.

RF technology uses unlicensed communications frequencies, meaning that flexible private networks can be configured, providing compliance with existing standards and approved communication frequencies in the country of use. Generally, less crowded and more reliable lower bandwidth radio frequencies are used (868/915/2450 MHz). Narrowband applications also use considerably less power, which makes the technology even more suitable for a cost-effective network.

Possible challenges:

RF technology has a number of limitations that make it unsuitable for specific applications, such as:

- **Shared resources** - the wireless spectrum is a limited resource and shared by all nodes in the range of its transmitters. Bandwidth allocation becomes complex with multiple participating users, in such conditions the individual user rate may lower down.
- **Interference** - compared to wired systems, wireless networks are frequently subject to electromagnetic interference. Interference caused by other networks or equipment generating radio waves within, or close, to the radio bands can degrade the signal.
- **Absorption and reflection** - some materials cause absorption of electromagnetic waves, preventing it from reaching the receiver, in other cases (with metallic or conductive materials) reflection occurs. This can cause dead zones where no reception is available.
- **Multipath fading** - due to reflection, two or more different routes may be taken, which affects the strength of the signal.
- **Collision** - occurring when a node is visible from a wireless access point (AP), but not from other nodes communicating with that AP, so the signals can interfere at some of the points, leading to difficulties in media access control.
- **Preliminary planning** - RF mesh networks often require careful network planning, especially in regard to the density of nodes and the placement of gateways. For these

reasons, initial implementation costs for RF mesh networks may be higher than they are for cellular networks, even if operational costs are lower.

To overcome the above-mentioned limitations a number of amendments to extend the original 802.15.4 standard were introduced. The IEEE 802.15.4g amendment defines three new physical layers enabling to extend the communication range and increase the reliability. It operates at sub-GHz frequencies, where the wireless signal can propagate at longer distances, with the same transmission power, introducing additional modulation schemes to compensate the effects of multi-path fading.

ADDAX solution aspects:

Like any system, PLC or RF have both advantages and disadvantages:

| | PLC technology | RF technology |
|-------------------|---|---|
| advantages | Ease of use | No wired lines from metering devices to data collection equipment |
| | Low installation and operating costs | Reduced operating and maintenance costs |
| | Registration of equipment as radio frequency is not required | Reading data from devices installed in hard to reach places |
| | Provides a mechanism to suppress the signal in a given range | The minimum number of settings, but, nevertheless, can be flexibly adapted to a wide range of tasks |
| drawbacks | Sensitivity to interference generated by low-quality consumer equipment | Limited frequency resource |

To get the best coverage and combine the advantages of PLC and RF technologies, ADD GRUP offers a hybrid solution based on the new STMicroelectronics development. This solution allows improving data collection and making it more reliable. If one of the systems fails for any reason, an automatic switch to the other will occur. The hybrid solution can be used in different countries, with diverse requirements for power grids.

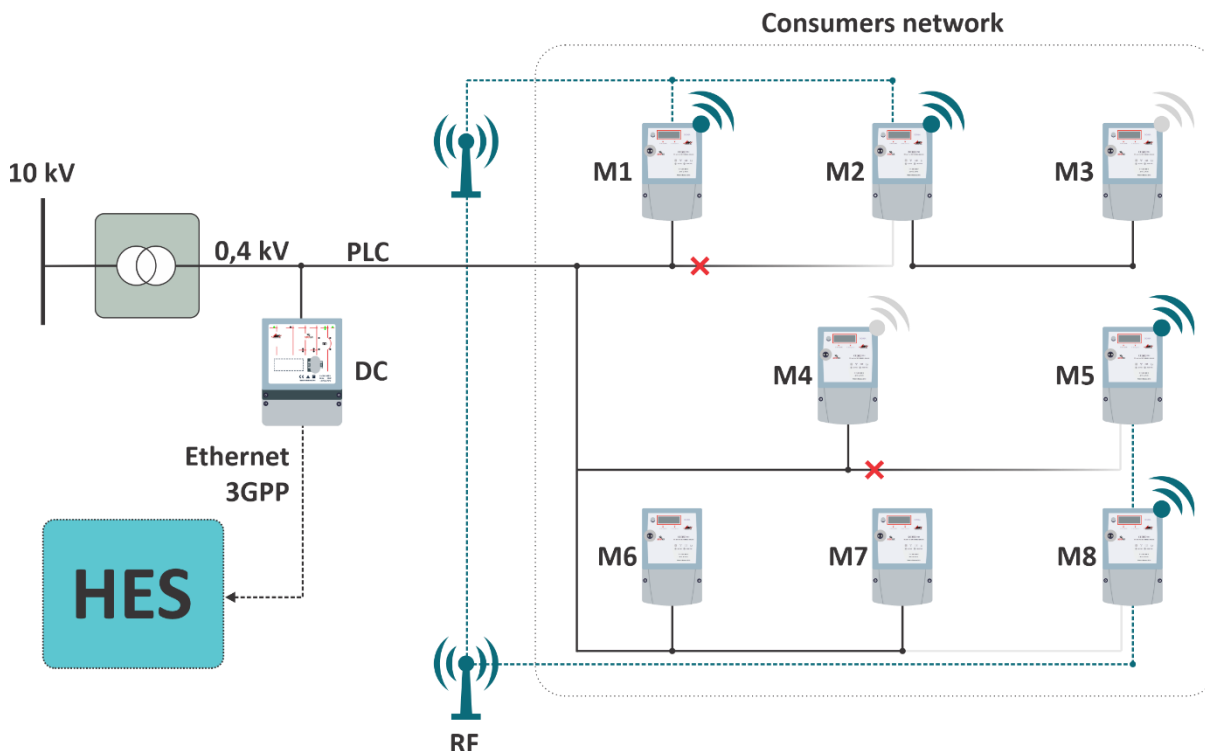

Figure 5. General scheme of data transmission via hybrid PLC+RF communication channel

ADDAX Hybrid (PLC+RF) solution is based on open standards and provides seamless integration into ADDAX AMI. The protocol stack is presented below:

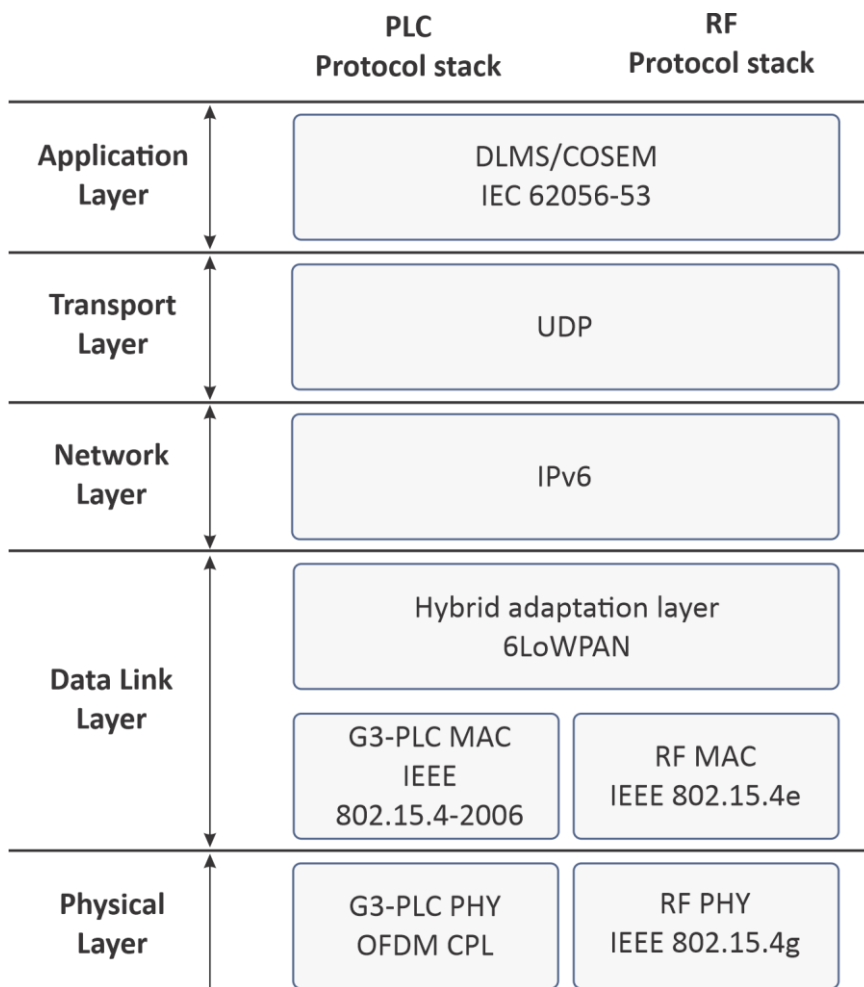

Figure 6. ADDAX hybrid protocol stack

The lower layers are based on G3-PLC specification. The G3-PLC data link layer is adapted for hybrid network.

The physical layer for PLC supports CENELEC A and FCC frequency bands. The band to be used as well as tone mask can be configured as required.

The physical layer for RF supports a large set of bands – from 430 to 1000 MHz. This covers all popular license-free bands for worldwide markets: 433 MHz, 868 MHz and 915 MHz.

The main goal of the 6LoWPAN adaptation layer is to optimize the transmission of IPv6 packets over low-power and noisy networks. The IPv6 layer provides for devices addressing, while UDP is used as a lightweight transport protocol.

Every meter has PLC+RF modems that enables connectivity to other meters. The route is built hop-to-hop, selecting between the best channel. The channel selection is dynamically adjusted based on media status. This provides for better meters availability in spite of the media conditions.

Combining all the advantages of PLC and RF systems into one-system makes the ADDAX hybrid solution the best choice for many purposes. The results of implemented projects based on PLC+RF hybrid solution show that the proposed system provides appreciable rate gains compared to standalone PLC or RF communication systems for the same amount of total transmission power. Such a system can help improve the performance, reliability, capacity and scalability of the network, which leads to additional savings during system exploitation.